

## INSTRUCTIONS FOR USE:

### ADJUSTABLE BOLSTER SAFETY SUPPORT TOOL

Capacity: This tool has a rated capacity of 600 lbs.

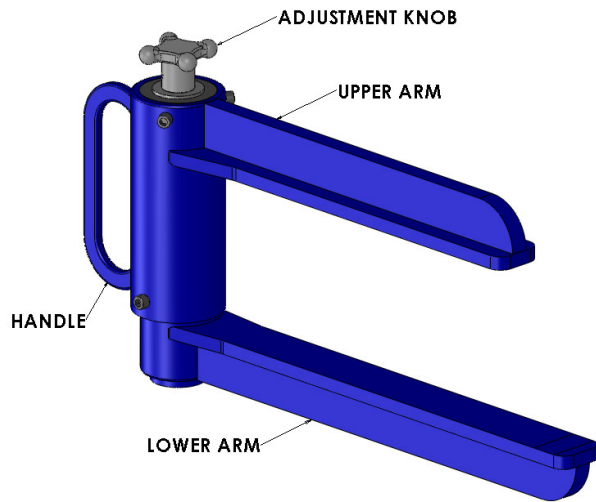

**FIGURE 1**



**FIGURE 2**

This lifter is designed as a secondary bolster support system to protect mechanics when they are performing truck spring, snubber, or wear plate replacement. It has no other intended uses.

### **ADJUSTABLE BOLSTER SECONDARY SUPPORT TOOL:**

WARNING: Ensure freight car(s) is/are properly secured with hand brakes and/or chocks before attempting to perform any truck repairs..

1. Inspect the tool for defects. Make sure the adjustment knob is in place and working freely. (Figure 1).



**FIGURE 3**



**FIGURE 4**

2. Raise the bolster until it contacts the side frame using an overhead crane, hoist, or a forklift with an approved lifting device.
3. Adjust the support tool as necessary to fit into the bolster casting and over the side frame. Turn the adjustment knob clockwise to close the tool, and counter-clockwise to open the tool (Figure 3).
4. Insert the long (lower) arm of the tool into the bolster casting using the handle provided on the tool. The short arm (upper) must go over the top of the side frame (Figure 3).
5. With the tool seated all the way into the bolster, turn the adjustment knob clockwise until it is tight against the bolster and side frame.(Figure 2).
6. If the bolster is raised on both sides, place a second tool on the opposite side of the bolster and install it using the same procedure.
7. Complete repairs as necessary while the bolster is secured. **The hoist or other lifting device must be left in place while repairs are completed** (Figure 4).
8. Open the tool by turning the adjustment mechanism counter-clockwise (Figure 3).
9. Remove the tool or tools from the bolster and place them back into their normal place of storage.

### **SAFETY PRECAUTIONS:**

WARNINGS: Noncompliance could cause injury to employees

CAUTIONS: Noncompliance could cause damage to equipment

NOTES: Pertinent information

1. WARNING: Wear personal protective equipment in accordance with Safety and General Conduct Rule 1040 as required.
2. WARNING: Always keep all parts of your body out from under and suspended equipment or load.
3. WARNING: Avoid pinch points. Never place your hand or fingers between the bolster, sides frames, or springs.
4. WARNING: **Always leave the crane or other lifting device attached to the bolster during repairs. Do not depend on this tool for primary bolster support.**
5. CAUTION: This tool is designed to support raised bolsters. It must never be used for any other applications..